



VERSO Air Handling Units



Energy efficient solutions for profitable indoor climate



VERSO Air Handling Units

- VERSO-S – air supply units
- VERSO-R – air handling units equipped with regeneration system
- VERSO-P – air handling units equipped with recuperation system



Purpose:

These are universal air handling units intended for ventilating various buildings:

- Service offices
- Health and medical buildings
- Educational institutions
- Industrial, manufacturing facilities



All technical information specified in this brochure is approximate and intended for general review of VERSO air handling units group. For more accurate figures, use our VERSO air handling unit selection software.

Sizes

The capacity of the air handling units ranges from 1 000 to 26 000 m³/h. Their maximum working pressure is 900 Pa. The air handling units come in eight sizes.

Thus, it is possible to choose a unit of optimal size according to the customer's needs.

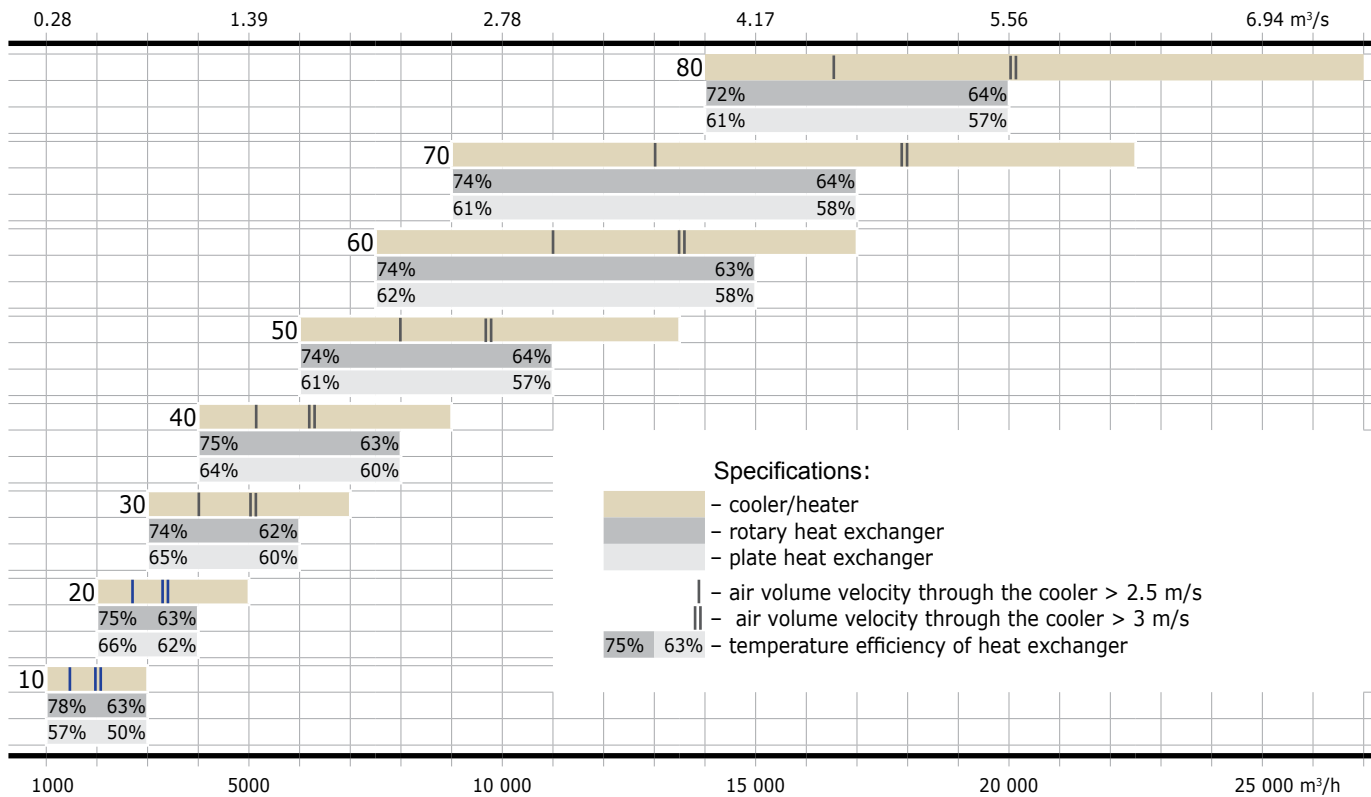

Specifications

XXXXXXXXXX

- Controller C3
- Air cooler (indicated if used):
 - CW (water) XR/ X/ X _____ number of circuits
 - _____ fin pitch
 - _____ number of rows
- XDX (direct) XR/ X/ X _____ number of circuits
- _____ fin pitch
- _____ number of rows
- _____ number of steps (indicated if > 1)
- Air heater (indicated if used):
 - HW (water) XR/ X/ X _____ number of circuits
 - _____ fin pitch
 - _____ number of rows
- HEX (electric) _____ capacity of electric heater (kW)
- Side of inspection IS1, IS2, IS3, IS4
- Air mixing section (indicated MS if section is used)
- Class of supply/exhaust air filter: G3, G4, F5, F7, F8/9
- Fan motor power supply/exhaust (kW)
- Plate spacing of heat exchanger (only VERSO-P): C-small, M-medium, L-large
- Rotary heat exchanger wave height (only for VERSO-R): L - 1,7 mm, M - 2,1 mm
- H - hygroscopic rotary heat exchanger (marked, if such rotor is used)
- Size unit 10÷80
- VERSO-S, VERSO-R, VERSO-P

VERSO-P-30-L-2,2/2,2-F5/G3-X-IS4-HW2R/3,0/2-CW/2R/2,5/2-C3
 VERSO-R-30-MH-2,2/2,2-F7/F7-MS-IS1-HE15-DX/1R/2,5/4-C3

VERSO Air Handling Units

Design

Unique VERSO-P, VERSO-R unit casing is comprised of three main sections. Two side sections – are completely symmetrical fan and filter sections that allow to choose desired design options and viewing side. The middle section is for heat exchanger. We offer two heat exchanger types: rotary and plate heat exchanger.

VERSO-S casing is composed of two symmetrical filter and fan sections.

For customer convenience air heaters, coolers and dampers are mounted outside the unit.

- **Safe and easy**

Unit design assures effective transportation and easy installation. Separate parts are compact, without projection parts; therefore it is easy to transport them to a designated area of the building, where later they are assembled. Finished air handling units are delivered to the customer in packages that are ready to be transported.

- **Long-lasting**

Unit doors are mounted with firm and aesthetic-looking hinges, are locked with convenient and elegant locks. Door seals are firm and elastic rubbers with air gap. They are mechanically fastened to the door and are long lasting and hermetic.

- **Effective and versatile**

Unit walls are made of galvanized steel sheets with 45 mm thickness insulation. This assures not only effective heat and noise insulation, but also high level of fire resistance. Air handling unit accessories – external grilles for supply/exhaust vents, hood and roof – allow installing units outside.

- **Comfortable and simple**

Filters, fans, heat exchangers, coolers and other components are easily accessible during use; if necessary, they can be easily replaced. New filter clamping mechanism, not only assures tightness, but also essentially simplifies filter change procedure.



Heat exchangers

Plate heat exchanger

Used by VERSO-P series units.

Temperature efficiency factor – up to 70%.

Aluminum plate-type heat exchangers are used in the units.

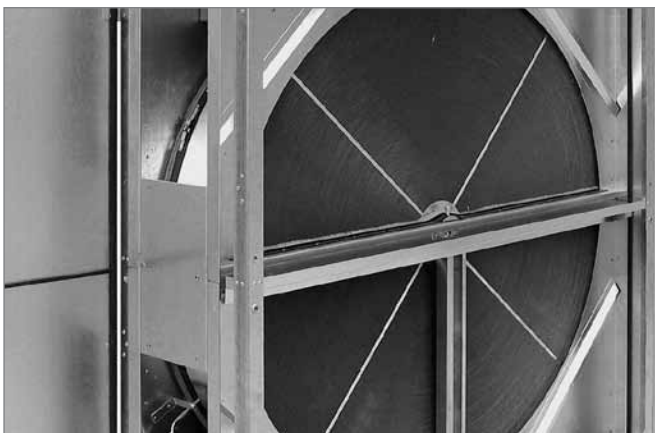

Rotary heat exchanger

Used by VERSO-R series units.

Temperature efficiency factor – up to 84%.

Possible wave height: 1,7 mm; 2,1 mm.

Types of rotary heat exchangers:

- Aluminium;
- Hygroscopic.

Rotary heat exchanger rotation speed is controlled by frequency converter, according to air temperature.

Rotation speed – up to 10 rpm.

Heat exchanger can be ordered with installed purge section.

Fans

In the VERSO series units Plug type fans are used, therefore, units are silent and use electricity effectively. Fans are balanced statically and dynamically, based on ISO 1940 standard; therefore, unit vibration is minimal and meets all requirements. While running, fans exhibit these qualities:

- very high efficiency coefficient;
- frequency converters ensure optimal capacity;
- good acoustic performance;
- longevity: fan is directly connected with the electric motor; therefore, is no belt gear, which simplifies maintenance. Fans are painted in epoxy paint – blue RAL 5002;
- there is a possibility to install air flow measuring device.

Fans are equipped with three-phase (400 V) motors and are controlled with frequency converter.

Safety category – IP55 according to IEC 34-5.

Windings insulation category – F.

Maximum operating temperature is 40°C.

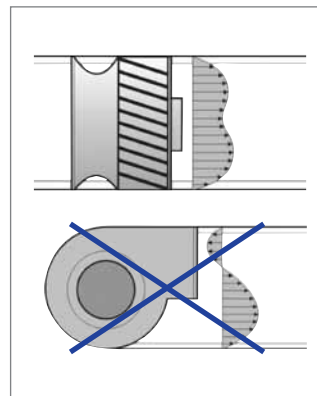
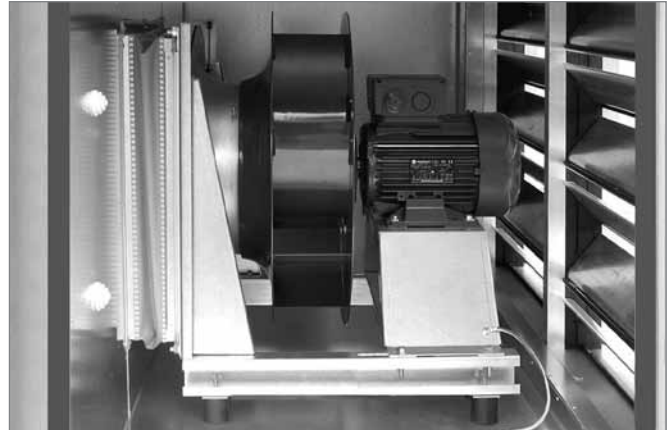

Air dampers

Closing air dampers installed in the air handling units are produced from aluminium, or galvanized steel blades with rubber sealing.

Connectors – L20.

For the unit sizes 60, 70, 80 – L30.



Air Filters

From G4 to F9 class synthetic or fiberglass pocket type filters are used.

- G3/4 class filters standard length – 200 mm.
- F5 class filters standard length – 300 mm.
- F6-F9 class filters – 500 mm.

Filter clamping mechanism secures tightness and simplifies filter replacement procedure.

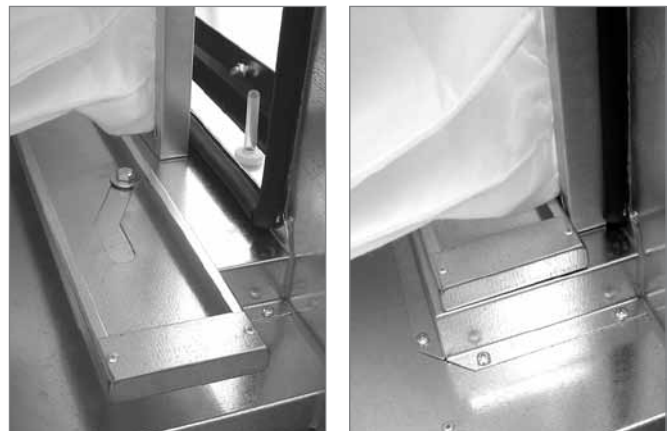

VERSO Air Handling Units



Air Heaters

Water Air Heaters

Normally used with aluminium fins (spacing 3 or 4 mm) and copper pipes. Can be made with thread joint to connect freezing sensor. Insulated with mineral wool heater section mounted on the outside of the unit – room space is saved this way; it is also more convenient to mount it.

- Maximum operating pressure – 10 bar.
- Maximum water temperature – +100°C. (on special order up to – +130°C).
- Heated air temperature up to – +40°C.



Electric Air Heaters

Three-phase (400V/50Hz) stainless steel heating elements are used in production. Three level protections ensure protection from overheating. Protection class IP55 in accordance with IEC 34-5. Heated air temperature up to – +400C.

Note: exact electric air heater measurements and other information can be found in VERSO air handling units selection software.



Air Coolers

Water Air Coolers

Normally used with aluminium fins (spacing 2,5 or 3 mm) and copper pipes. Insulated with mineral wool heater section mounted on the outside of the unit – room space is saved this way and it is more convenient to mount it.

Maximum operating pressure – 10 bar. Air cooler section can be assembled with sloping drain tray and water trap.

Direct Evaporation Air Coolers

Normally used with aluminium fins (spacing 2,5 or 3 mm) and copper pipes. Insulated with mineral wool heater section mounted on the outside of the unit – room space is saved this way; it is also more convenient to mount it.

Maximum operating pressure – 10 bar. Cooler section can be assembled with sloping drain tray and water trap.

Power of direct evaporation air cooler can be divided into steps. It is necessary to indicate this upon order.

Casing and Outside Grilles

Casing and outside grilles can be additionally mounted onto supply and exhaust vents of the air handling units that are designed to be used outside.



Roof

Roof with water drainage to the side opposite from the viewing side can be additionally installed on air handling units that are designed to be used outside.



Height Adjustable Feet

Ordered construction frame of the air handling unit with height adjustable feet makes it much easier to level the unit at the site.

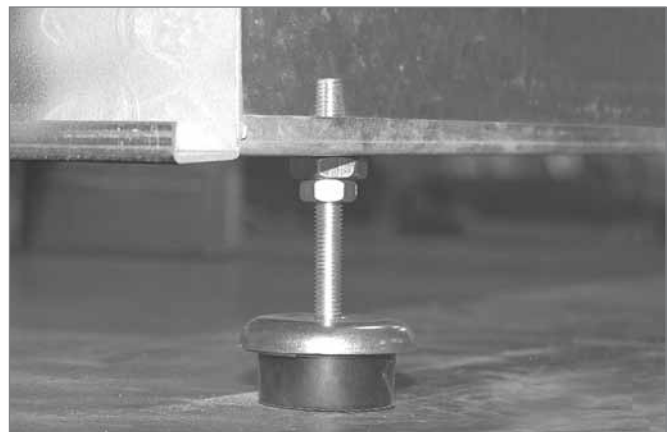

Door Locks and Handles

Easy to use door locks and handles ensure safe unit maintenance.



VERSO Air Handling Units

Dimensions

Modern air handling unit proportions allow reaching better technical parameters: lower air flow velocity inside the unit, better acoustic data. Shortest length between analogues ensures compactness; therefore air handling units are easier to design and install.

VERSO-S

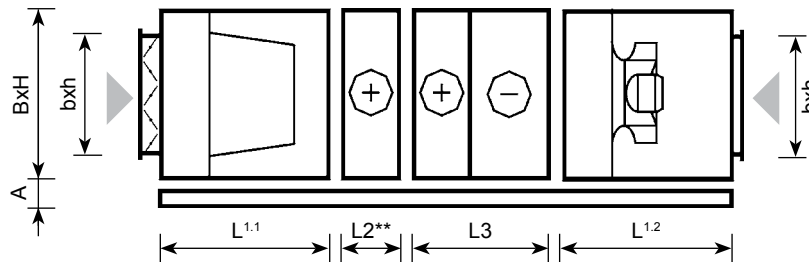

Size	B	H	L ^{1.1}	L ^{1.2}	L3	b	h	A
10	1000	490	705	705	710	900	400	125
20	1150	585	705	705	710	1100	500	125
30	1300	660	705	705	710	1200	600	125
40	1500	740	705	842	710	1400	700	125
50	1700	890	705	842	710	1600	800	125
60	1900	960	705	979	710	1800	900	125
70	2100	1085	705	979	710	2000	1000	125
80	2300	1185	705	1300	710	2200	1100	125

L2** - 165...370 mm depending on selected air heater.

Note: electric air heater section length is noted in VERSO air handling unit's selection program.

VERSO-R

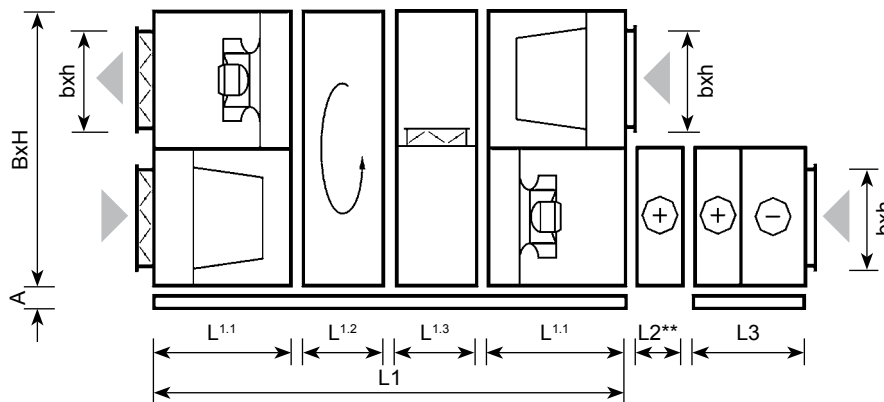

Size	B	H	L1	L ^{1.1}	L ^{1.2}	L ^{1.3}	L3	b	h	A
10	1000	1000	2100	618	432	432	710	700	300	125
20	1150	1150	2386	751	432	432	710	900	400	125
30	1300	1300	2386	751	432	432	710	1000	500	125
40	1500	1520	2386	751	432	432	710	1200	600	125
50	1700	1715	2634	885	432	432	710	1400	700	125
60	1900	1920	2769	885	432	567	710	1600	800	125
70	2100	2100	2906	885	432	704	710	1800	900	125
80	2300	2420	3771	1250	430	841	710	2000	1000	125

L2** - 165...370 mm depending on selected air heater.

Note: electric air heater section length is noted in VERSO air handling unit's selection program.

VERSO-P

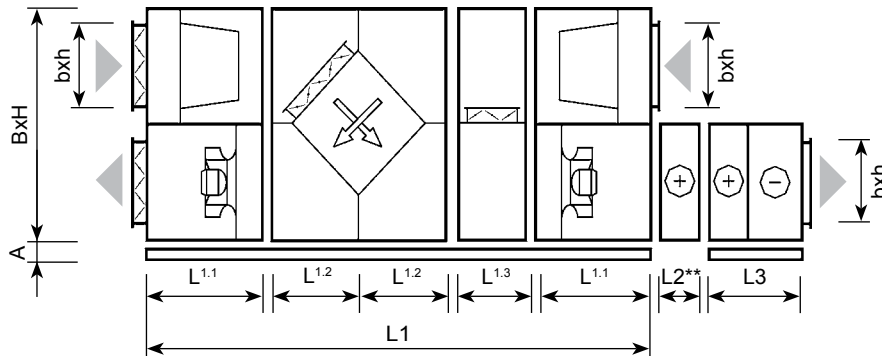

Size	B	H	L1	L ^{1.1}	L ^{1.2}	L ^{1.3}	L3	b	h	A
10	1000	1000	2511	618	422	432	710	700	300	125
20	1150	1150	3074	751	570	432	710	900	400	125
30	1300	1300	3074	751	570	432	710	1000	500	125
40	1500	1520	3074	751	570	432	710	1200	600	125
50	1700	1715	3618	885	707	432	710	1400	700	125
60	1900	1920	4025	885	845	567	710	1600	800	125
70	2100	2100	4162	885	845	704	710	1800	900	125
80	2300	2420	5261	1250	1150	841	710	2000	1000	125

L2** - 165...370 mm depending on selected air heater.

Notes: size 20+80 plate heat exchanger section is made of two parts. Size 10 - from one part.

Electric air heater section length is noted in VERSO air handling unit's selection program.

Composing Options:

IS-1

Air handling unit viewing doors are on the right; supplied airflow is on the bottom of the unit.

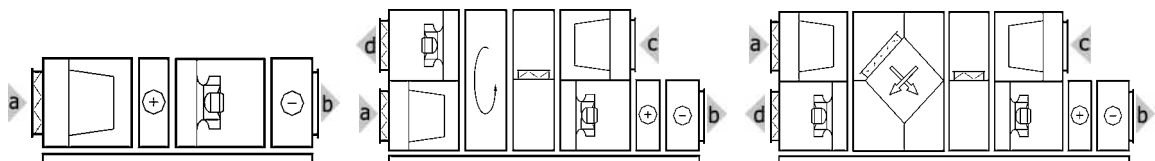

IS-2

Air handling unit viewing doors are on the left; supplied airflow is on the bottom of the unit.

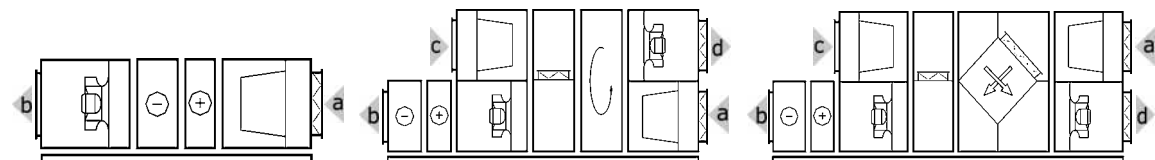

IS-3

Air handling unit viewing doors are on the right; supplied airflow is on the top of the unit.

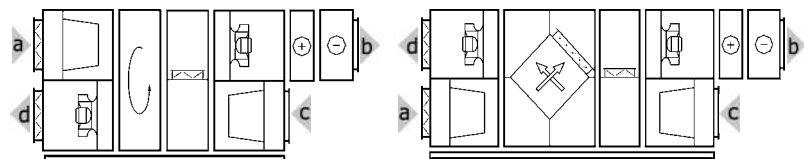

IS-4

Air handling unit viewing doors are on the left; supplied airflow is on the top of the unit.

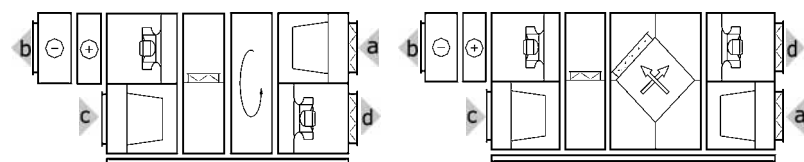

a outdoor intake
 b supply air
 c extract indoor
 d exhaust air

VERSO Air Handling Units

Control System

Integrated control system ensures safe operation of the air handling unit, controls preset ventilation system parameters, and optimise unit operating costs. To lower unit instalment and operating costs, automatic unit control system was designed. The system connects the elements and allows quickly assembling and connecting unit parts together. KOMFOVENT C3 controllers are used in VERSO air handling units.



Operating Functions	Description
Unit control using panel	Panel can be used to control unit operation: to change operation modes and parameters, to switch unit on or off anytime
Remote switching on or off	Possibility to switch unit on or off using additional device
Supply air temperature maintenance	Unit automatically supplies air according to temperature preset by the user
Room temperature maintenance	Unit automatically supplies air of such temperature to maintain preset room temperature (15...30°C)
Temperature maintaining mode setting	Option to displace set value of the supply or room air temperature for the specified time period
Automatic temperature maintaining mode selection	Depending on the outdoor temperature, maintaining mode can be selected automatically
Ventilation intensity control	User may set most economical and effective ventilation intensity level
Constant air volume control (CAV)	Unit maintains set by the user supply and exhaust air volume
Variable air volume control (VAV)*	Unit supplies and exhausts air volume correspondingly to the ventilation requirements in different premises. In case of frequently changing ventilation demands this air volumes maintenance mode signally reduces unit exploitation costs
Ventilation intensity control option according to external sensor signal*	Provided ventilation intensity correction, according to increased CO ₂ , humidity level and etc.
Ventilation correction in winter time	In winter time, if there is not enough heating power, temperature is maintained by decreasing ventilation intensity
Unit weekly schedule programming	Weekly operation schedule with three daily events may be set. For each daily event, user can select ventilation rate or maintained pressure
Unit operation mode selection	In automatic mode the unit is operated according to weekly schedule. In manual mode the unit operates by set intensity constantly
Season setting	For the unit to operate in the most economic mode, summer and winter settings are provided
Automatic season change	Depending on the outside temperature, season can be selected automatically
Pump control	Water pump is controlled depending on the outside temperature and according to the need
Cooling energy recovery	In summer time, cooling energy is recovered to the room
Exhaust air flow correction*	User for the set time period can adjust exhaust air fan speed

OVR function*	OVR – Override. 4th ventilation level activation via external contact. Function has the highest priority and operates in every mode, even the unit is switched off. It is provided intensity adjusting of 4 th ventilation level for supply and exhaust fan separately.
Protection functions	Description
Water heater frost protection	Maximally decreases water frost possibility
Electric heater overheating protection	If there is danger of overheating, heater shuts down automatically Unit is equipped with heater cooling. When unit is shut down during the heating operation, fans will continue to operate for set time period
Plate heat exchanger frost protection	When there is low outdoor temperature, heat exchanger is protected from freezing
Fan overheating protection	Fan motor is protected from failure
Rotary heat exchanger rotation guard	If heat exchanger has a failure, the unit operation is stopped
Emergency shut down in case of fire	If the unit is connected to the building fire-alarm system, in case of fire unit operation is stopped automatically
Emergency shut down according to the temperature value limits	If supply air temperature reaches emergency level, unit operation is stopped
Distance unit failure indication	Possibility to indicate about the unit failure anywhere
Other functions	Description
Filter clogging indication	In case of at least one filter clogging, warning appears on the panel display
Mode operation, temperature and time indication	User can monitor the processes on the control panel
Failure indication	In case of failure of a separate unit assembly or elements, the air handling unit is stopped. This is indicated by text message
Language selection	Control panel provides menu for the language selection
Air flow indication	Option to monitor unit supply and exhaust air flow (m ³ /h)
PC unit control*	Option to manage and control units by computer, when connected to the PC network, or Internet

* additionally ordered function



More specific information about a specific unit can be obtained using VERSO air handling unit operating program, which can be downloaded from www.komfovent.com webpage.

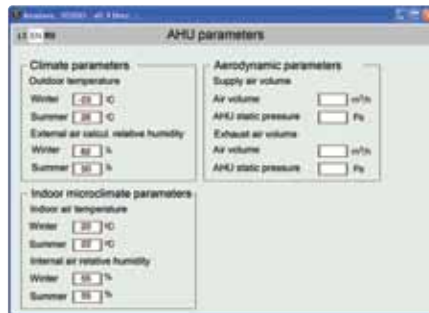
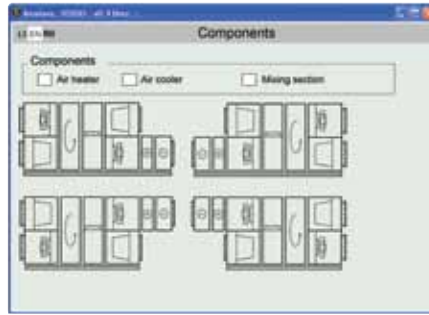
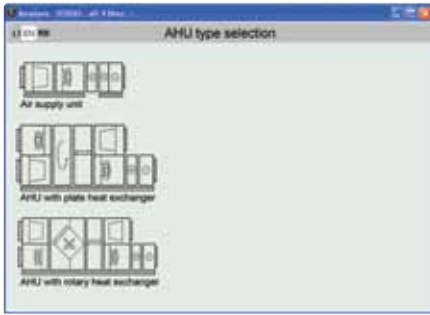

To monitor and control units, VERSO air handling units control program has been created.

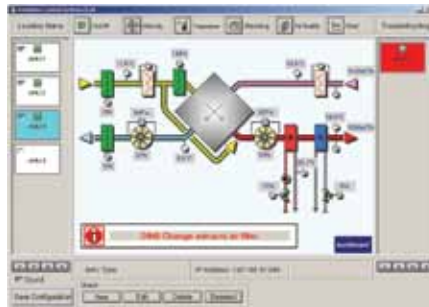
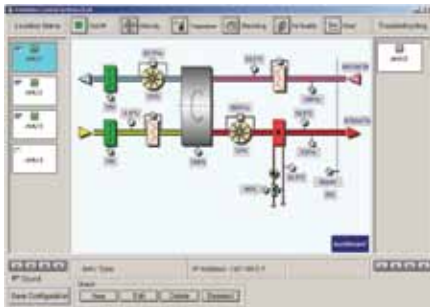

KOMFOVENT producer:

UAB AMALVA
 Ozo str.10, LT-08200 Vilnius, Lithuania
www.komfovent.com, info@komfovent.com

