

Energy Meter

Model No. AEHT-09999



Introduction

With the Energy Meter, you are now able to determine power costs of your power loads in the easiest way.

Proper use

The measurement range of the Energy Meter extends from 5 to 3680W. If values fall below or exceed these limit values, exact measurements are no longer possible. Also the device could be overloaded and thereby destroyed.

The Energy Meter has been developed for monitoring and measuring electrical loads.

- The Energy Meter is only certified for operation at 230V AC.
- Only power loads with a power supply of 230V AC 50/60Hz may be connected.
- The maximum power of any connected load may not exceed 3680W (max. current 16A).
- Operation of the Energy Meter is only permitted in interior spaces and dry environments, Usage in the open air is strictly forbidden!
- Always observe the declaration on the identification labels of connected power loads.

Another use than the one described above may lead to damage to the product and may be associated with dangers like short circuit, fire, electric shock, etc. The entire product may not be converted or modified! The safety instructions must be strictly observed.

Safety Instructions

- The manufactures will not assume any liability for damages to items or persons caused by improper handling or non-compliance with the safety notices! Any warranty claim will become null and void in such cases.
- It must be observed that the conductive ground wire is not broken as this can pose lethal danger in the event of a malfunction.
- This device is not a toy and does not belong in the hands of children.
- Only connect the Energy Meter to certified protected contact outlets 230V AC 50/60Hz (10/16A) with a ground wire.
- The connected load may not exceed 3680W(16A).
- The commended operating temperature is between +10 and +40 °C. High temperatures, especially during measurement of large power loads, lead to danger of overheating and can thereby permanently destroy the Energy Meter.
- Avoid operating under adverse environmental temperatures and near flammable gases, vapour and dust
- For reasons of safety, never allow the device to be operated when wet or in a damp environment
- When cleaning or servicing, the device must be disconnected from every source of operation voltage. Condensers in the device may still be charged, even if the device was disconnected from all voltage sources.

- In schools, training facilities, hobby and self-help workshops, qualified personnel must supervise the operation of measurement units.
- In commercial institutions, make sure you observe the accident prevention regulations of the commercial trade organization for electric installations.
- Do not insert needles, metals or any other objects into the device.
- If it has been ascertained that safe operation is no longer possible, take the device out of operation and secure it against accidental reactivation. It can be ascertained that safe operation is no longer possible if the device shows visible damage, no longer works correctly, has been stored for a long period under unfavorable conditions or has been placed under heavy stresses in transport.

Properties

- Display of current time (24 hours type), week, load power and cost tariff.
- Display of total on time, total used energy and accrued energy cost.
- Display of total record time, total on time and percentage.
- Dual programmable power tariffs.
- Displaying line of power Blinks (fig4, the second line) if the load power is over 3680W

Connection, operation settings

Before you connect the Energy Meter to an outlet or power or power load, condensers in the device will be charged. Five minutes later, the condensers will have enough power to sustain the normal display of LCD then the current time and your desired power tariff must be set.

Note: you should take at least 12 hours to charge the condensers fully.

The procedure for entering the time and power tariff is described as following:

A. The setting of current time and week

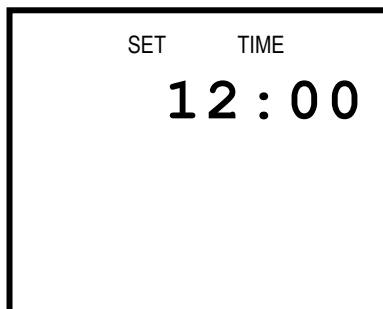

[fig1](#)

- 1, Press “+” “-“ buttons together to enter into system setting, first setting is the current time.
- 2, With “+” button to increase the value of the blinking position from 0 to 9, while with “-“ button to decrease the value of the blinking position.
- 3, Press “MODE” button to select next position.
- 4, After the setting of week, press “MODE” button, the system will enter into the setting of cost tariff 1.

B. The setting of cost tariff 1

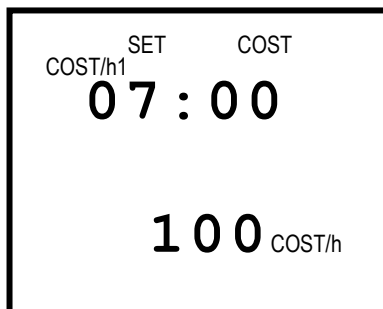

[fig2](#)

- 1, Set the effect time of cost tariff 1.
- 2, Set the value of tariff 1.(it is cent as unit, such as: 10cent)
- 3, With “+” button to increase the value of the blinking position from 0 to 9, while with “-“ button to decrease the value of the blinking position.
- 4, Press “MODE” button to select next position.
- 5, Press “MODE” button, the system will enter into the setting of cost tariff 2.

C. The setting of cost tariff 2

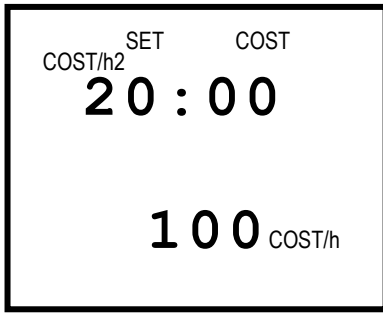

fig3

- 1, Set the effect time of cost tariff 2.
- 2, Set the value of tariff 2. (it is cent as unit, such as: 10cent)
- 3, With “+” button to increase the value of the blinking position from 0 to 9, while with “-” button to decrease the value of the blinking position.
- 4, Press “MODE” button to select next position.
- 5, Stop pressing longer than 5 seconds, it will confirm all your setting and quit to display board.

D. Press “MODE”, “+” “-” simultaneity to delete all data(the data of current time and the week will not be deleted) after 5 seconds.

Introduction of display board

Three display boards are designed to display different figures, you can use “MODE” button to select which board you want to browse.

1, Display of current time (24 hours type), week, load power and current cost tariff

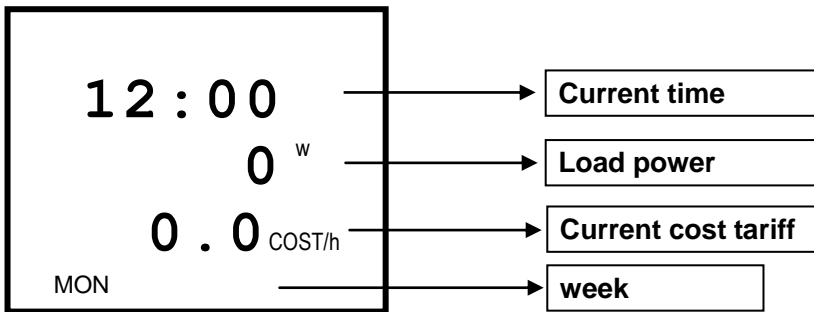

fig4

2, Display of total record time, total used energy and accrued energy cost.

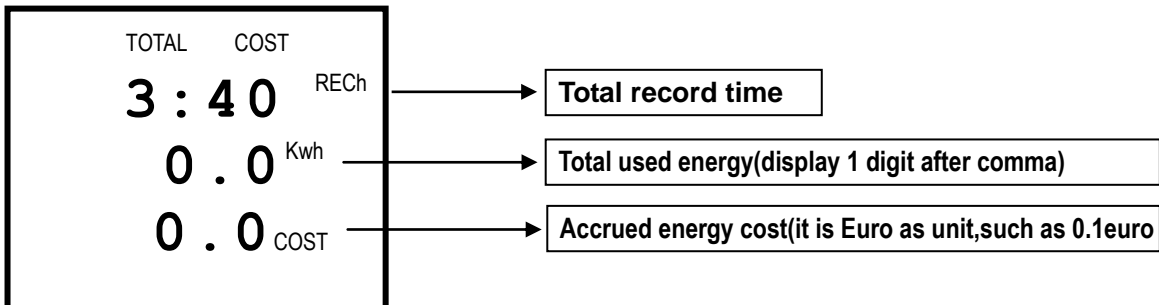
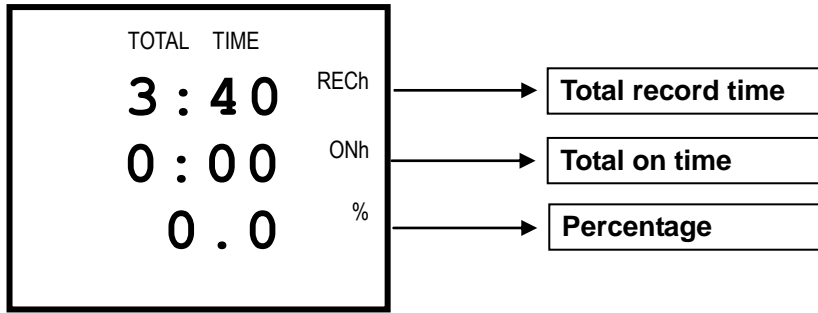

fig5

3, Display of total record time, total on time and percentage



[fig6](#)

Technical data

Working voltage: 230VAC 50/60Hz.

Max load: 16A.

Rating voltage: 230V.

Rating current: 0.00A-16.00A.

Display power: 5VA-3680VA.

Energy display: 0.1kwh-999.9kwh.

Max bit for time: 999.9 hours.

Using indoor only, altitude under 2000m

Working temperature: + 5°C to +40°C

Working humidity: 80% under 31°C, from 31°C to 40°C, this figure decreases to 50% linearly.

IP20

Pollution degree: II

Notes: Only one Energy Meter can be used in the same time, plug one socket into another one is permitted.

Maintenance

- Regularly inspect the Energy Meter for damages
- For cleaning the device and LCD, only use a dry, soft cloth. Do not use any cleaning solutions.
- Never immerse the device in water
- Maintenance or repairs may only be performed by a technician familiar with associated regulations.

Declaration: if the equipment is used in a manner not specified by the manufactures, the protection provided by the equipment may be impaired.